

DISCLAIMER: The use of this standard is governed by the "Texas Engineering Practice Act". No warranty of any kind is made by TxDOT for any purpose whatsoever. TxDOT assumes no responsibility for the conversion of this standard to other formats or for incorrect results or damages resulting from its use.

DATE: FILE:

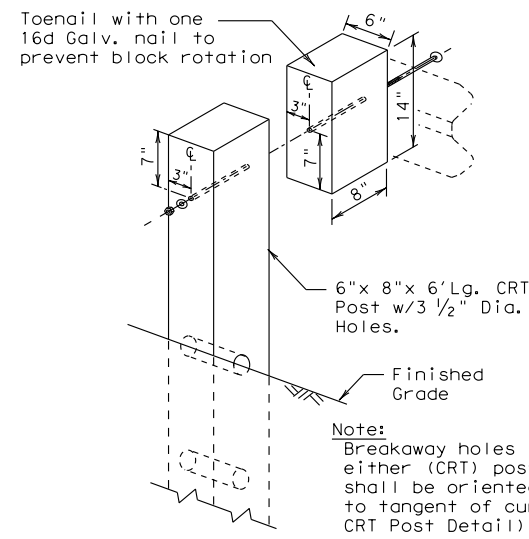

**WOOD BLOCK TO RECTANGULAR WOOD (CRT) POST**  
Showing the required 3 1/2" Dia. holes.

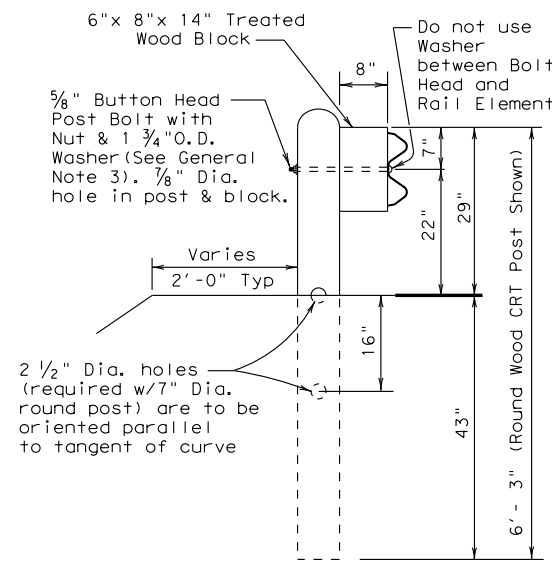

**(CRT) POST DETAIL CONTROLLED RELEASE TERMINAL POST**

Two or more wood CRT post(s) are required at any radius installation located at intersecting roadways or driveways.

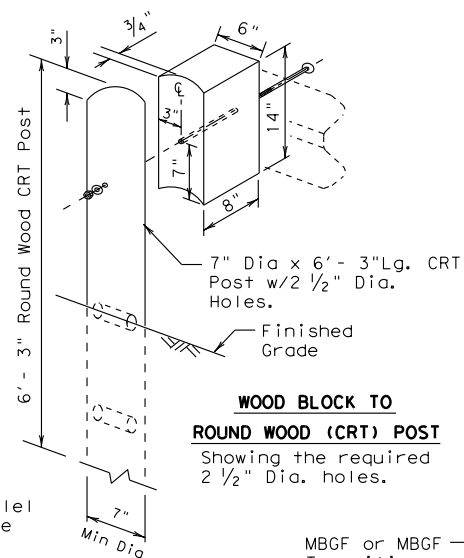

**WOOD BLOCK TO ROUND WOOD (CRT) POST**  
Showing the required 2 1/2" Dia. holes.

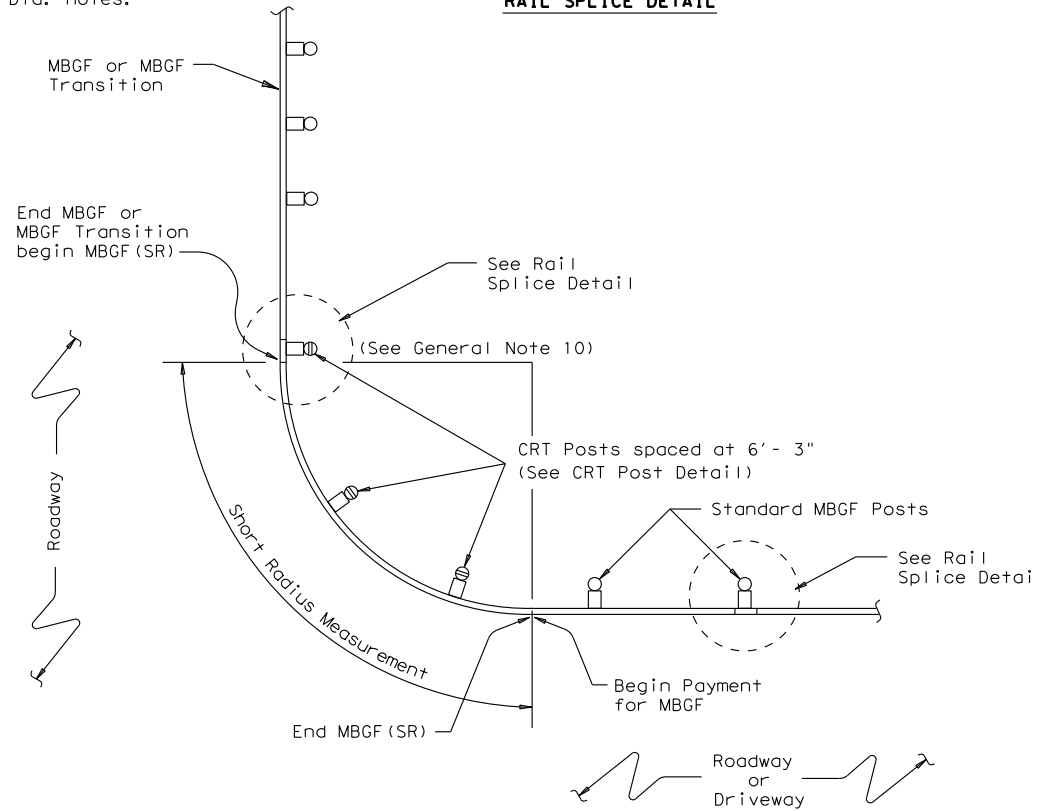

**PLAN VIEW SHOWING TYPICAL RADIUS**

The required radius is shown elsewhere on the plans.

**GENERAL NOTES**

- The type of (CRT) post (round wood post, or rectangular wood post) will be shown elsewhere in the plans. The exact position of MBGF shall be shown elsewhere in the plans or as directed by the Engineer.
- Steel posts are not permitted at CRT post positions.
- Rail element shall meet the requirements of Item 540, "Metal Beam Guard Fence" except as modified on the plans. The Contractor may furnish rail elements of 12 1/2' or 25' foot nominal lengths.
- Button head "post" bolts (ASTM A307) shall be of sufficient length to extend through the full thickness of the nut (ASTM A563) and Type A (1 3/4" O.D.) washer and not more than 1" beyond it. Button head "splice" bolts (ASTM A307) are 5/8" x 1 1/4" (or 2" long at triple rail splices) with a 5/8" double recessed nut (ASTM A563).
- Fittings (bolts, nuts, and washers) shall be galvanized in accordance with Item 445, "Galvanizing." Fittings shall be subsidiary to the bid item.
- Crown shall be widened to accommodate the Metal Beam Guard Fence.
- The lateral approach to the guard fence, shall have a slope rate of not more than 1V:10H.
- Unless otherwise shown in the plans, guard fence placed in the vicinity of curbs shall be positioned so that the face of curb is located directly below or behind the face of the block. Rail placed over curbs shall be installed so that the post bolt is located approximately 21 inches above the gutter pan or roadway surface.
- If solid rock is encountered within 0 to 18" of the finished grade, drill a 22" dia. hole, 24" into the rock, or drill two 12" dia. front to back overlapping holes, 24" into the rock. If solid rock is encountered below 18", drill a 12" dia. hole, 12" into the rock or to the standard embedment depth, whichever is less. Any excess post length, after meeting these depths, may be field cut to ensure proper guardrail mounting height. Backfill with a cohesionless material.
- Guardrail posts shall not be set in concrete, of any depth.
- Special rail fabrication will be required at installations having a curvature of less than 150 ft. radius. The required radius shall be shown on the plans.
- The terminal anchor section (TAS) post shall be set in Class A concrete (unless otherwise shown in the plans) in accordance with Item 421, "Hydraulic Cement Concrete." Concrete shall be subsidiary to the bid item requiring construction of the terminal anchor section (TAS). Terminal anchor post to be galvanized in accordance with Item 445, "Galvanizing."
- Unless otherwise shown in the plans, a composite material post and/or block that meets the requirements of DMS-7210, "Composite Material Posts and Blocks for Metal Beam Guard Fence" may be substituted for posts and/or blocks of similar dimensions. The Construction Division, TxDOT maintains a Material Producer List (MPL) for producers of materials conforming to DMS-7210. Only producers on the MPL can furnish composite material posts and/or blocks.

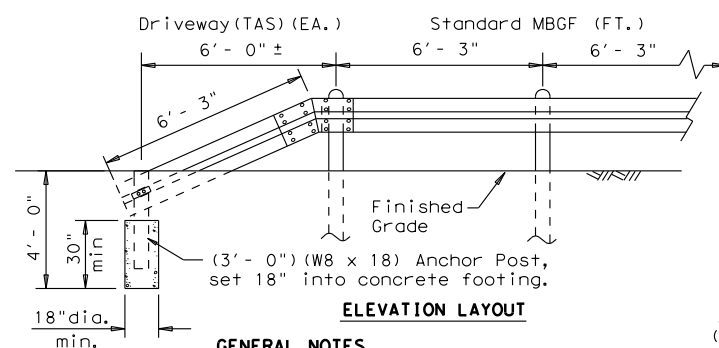

**ELEVATION LAYOUT**

**GENERAL NOTES**

- The "Driveway" Terminal Anchor Section is ONLY to be used within driveway locations, where the ROW is limited and a standard 25 ft. (TAS) Terminal Anchor Section, is too long.
- Terminal anchor post shall be set in Class A concrete.
- All steel shall be galvanized after fabrication in accordance with Item 445, "Galvanizing."

**"DRIVEWAY" TERMINAL ANCHOR SECTION**

Only for use within driveway locations, where a standard (TAS) Terminal Anchor Section can not be installed.

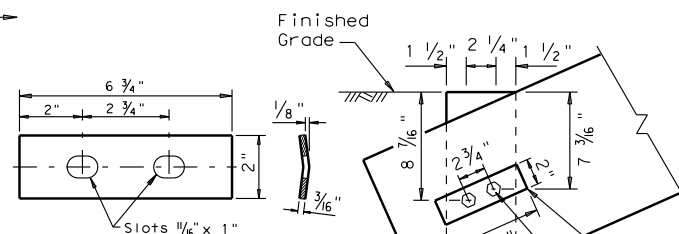

**PLATE WASHER FOR METAL BEAM**  
(Galvanized after fabrication)

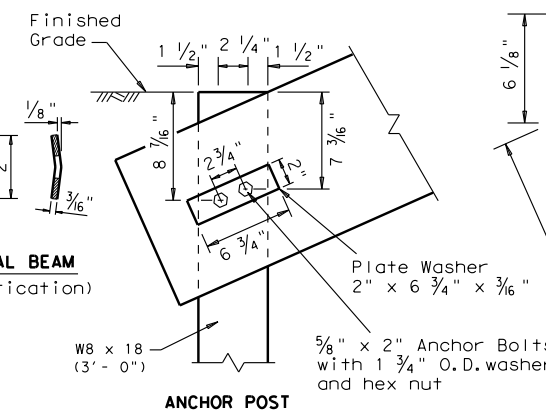

**ANCHOR POST**

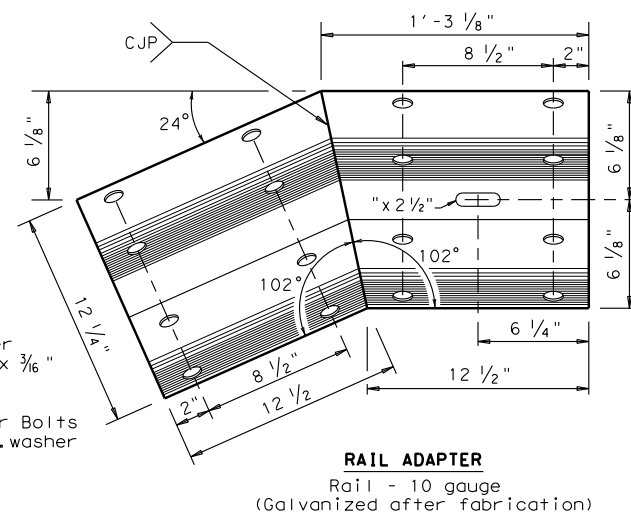

**RAIL ADAPTER**  
Rail - 10 gauge  
(Galvanized after fabrication)

		<b>Design Division Standard</b>	
<b>METAL BEAM GUARD FENCE (SHORT RADIUS) MBGF (SR) - 11</b>			
FILE: mbgfsr11.dgn	DN: TxDOT	CK: AM	DW: BD
© TxDOT June 2010	CONT	SECT	JOB
REVISIONS	DIST		COUNTY
12-2011	SHEET NO.		